



**catch the energy.  
save the money.  
save the environment.**



wind turbine system



solar system



## Information

### Strong reliability

- High level of availability, reliability and capability adopting Steiner's proven gearbox and generator technology
- Maximized turbine lifespan based on reliable structural design
- Continued focus on reliability and safety including two independently operated braking systems

### Excellent power production

- Independent electrical pitch drive system for minimum blade fatigue
- Highly efficient double fed induction generator and control system allowing for optimized operating efficiency
- Variable speed power regulation for maximum productivity

### Customer focused service

- Access-friendly design improving ease of maintenance
- SCADA system allowing for real time monitoring and control from remote locations
- Professional and prompt maintenance service resulting in world class reliability

### Total Quality Assurance

Steiner's total quality commitment to its customers is demonstrated by providing high quality products at competitive prices meeting its customers' project timelines.

Steiner Technology achieves this high quality record and worldwide reputation for quality through the integrated quality assurance and quality control program.

From design to assembly, testing, and installation Steiner Technology supports the customers' goals and visions with high quality products.



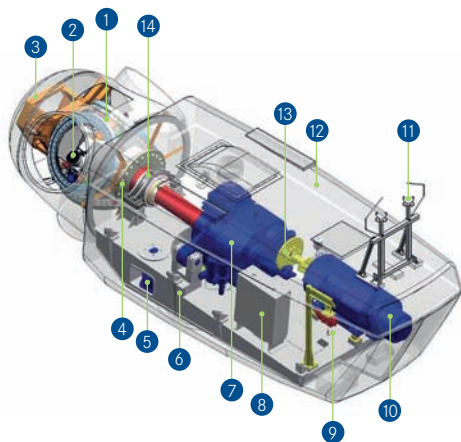

- 1 Hub
- 2 Pitch drive
- 3 Nose cone
- 4 Rotor lock
- 5 Yaw drive
- 6 Frame
- 7 Gearbox
- 8 Control panel
- 9 Winch
- 10 Generator
- 11 Wind sensor
- 12 Nacelle cover
- 13 Brake + coupling
- 14 Bearing housing

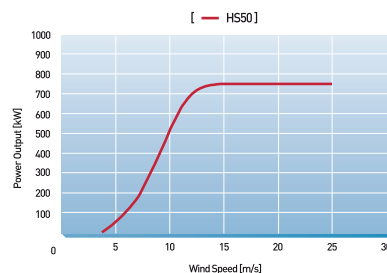

## HS50 – 750 kW and 850 kW wind turbines

### Operating data

Wind class	I a
Cut-in wind speed	4 m/s
Cut-out wind speed	25 m/s
Rated wind speed	12.5 m/s
Hub height	50 m

### Rotor

Power regulation	Variable speed Pitch regulated
Rotor diameter	50 m
Number of blades	3
Rotor speed	19.5 – 30.4 rpm

### Generator

Type	Double Fed Induction Generator
Voltage	690 V
Rated power	750 kW
Rated speed	1980 rpm

### Gearbox

Type	1 Planetary 2 Helical
Cooling	Air-cooled
Gear Ratio	$i = 70.7$

### Tower

Type	Tubular steel
Height	49 m

### Additional

Ambient Temp.	-10/40 °C -20/50 °C (idling or parked)
Monitoring	SCADA



## Wind power systems of Steiner Technology Group and their partners

- Planning
- Projectmanagement
- Financing
- Delivery
- Installation
- Starting up
- Service and
- Maintenance

of complete wind power systems and windparks of all power levels with international purchasing.

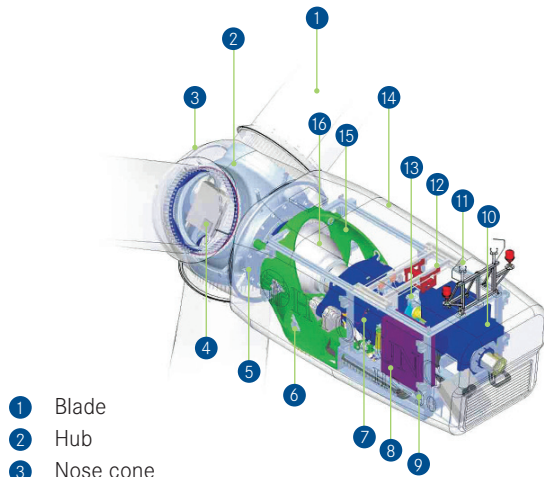

- 1 Blade
- 2 Hub
- 3 Nose cone
- 4 Pitch system
- 5 Rotor lock
- 6 Yaw drive
- 7 Gearbox
- 8 Control panel
- 9 Auxiliary frame
- 10 Generator
- 11 Wind sensor
- 12 Winch
- 13 Brake + coupling
- 14 Nacelle cover
- 15 Main frame
- 16 Bearing housing

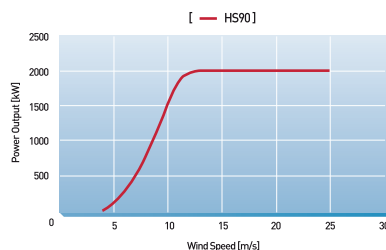

### HS90 – 2 MW wind turbine

#### Operating data

Wind class	II a
Cut-in wind speed	4 m/s
Cut-out wind speed	25 m/s
Rated wind speed	11 m/s
Hub height	77 m

#### Rotor

Power regulation	Variable speed Pitch regulated
Rotor diameter	90.6 m
Number of blades	3
Rotor speed	10.9 – 18.1 rpm

#### Generator

Type	Double Fed Induction Generator
Voltage	690 V
Rated power	2000 kW
Rated speed	1980 rpm

#### Gearbox

Type	1 Planetary 2 Helical
Cooling	Air-cooled
Gear Ratio	$i = 125$

#### Tower

Type	Tubular steel
Height	74 m

#### Additional

Ambient Temp.	-10/40 °C -20/50 °C (idling or parked)
Monitoring	SCADA



## Introduction

From producing silicon, from design to implementation, from financing to maintenance– SunPower is the one-stop shop for renewable energy solutions.

SunPower offers turn-key solutions in photovoltaic, solar thermal, small wind, biomass and hybrid technologies utilizing unparalleled engineering expertise and the highest standards in terms of quality, efficiency and services. SunPower is a one hand System Integrator for all kind of renewable energy solutions. SunPower produces own Solar cells from own SI Metal in a special new plant.

SunPower shall become a key player in the German and European markets within 5 years, and shall also expand its business activities to the South & North American and African continents. SunPower will established branches in the USA, South America and Africa. SunPower has the plan to build a own Factory for the production of SI Metal in South America incl. a production line for solar cells.

Leveraging our experience by the employees and origin manufacturers for turn-key systems worldwide, we offer our customers outstanding engineering services individually customized to their needs with high quality products, superior support and extensive consulting services. SunPower's expertise is as broad as it is deep, encompassing projects as varied.

The core of our philosophy is to be close to our customers in order to understand their needs. We do more than provide a great product – with professionalism and speed we provide complete energy solutions that are not only practical and economically attractive, but also help create a better world.



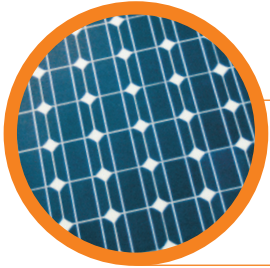

## Photovoltaic – Operating mode

In this manner, a sufficiently high amount of tension and energy is produced to supply an entire household with electricity. But before the energy from sunlight can be used, it must be processed. The photovoltaic cells deliver direct current, which has to be transformed into useable 50 Hz alternating current by a static converter. In the case of autonomous installations, the solar produced energy is stored in batteries. That's how a reliable energy supply is guaranteed even at night or at times of reduced sunlight.

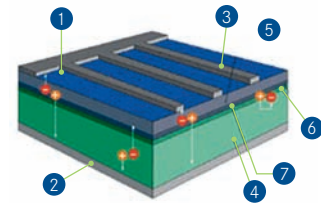

- 1 Anti-reflex layer
- 2 Back contact area (positive electrode)
- 3 Front contact area (negative electrode)
- 4 Positive endowed silicon
- 5 Negative endowed silicon
- 6 Space charge area
- 7 Dividing layer



- 1 PV generator
- 2 DC disconnect
- 3 Solar cable
- 4 Inverter
- 5 System monitor
- 6 Utility meter
- 7 Grid connection



## SolarPower products of Steiner Technology Group

- Solar plants for private customers
- Solar plants for public customers
- Solar parks for villages and cities (big future market)
- Combined solar and heat (combined heat and power generation)
- Mobile solar plants (power modules) – combined with drinking water abstraction
- New development of a complete electrical drive system (solar) for trams with loading stations at the stopovers, powered by solar modules

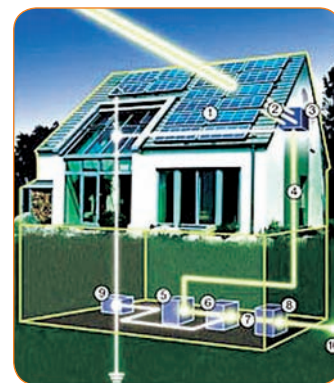

- 1 Solar modules
- 2 Module connections
- 3 Alternator connection box
- 4 DC main line
- 5 DC connection/clearing
- 6 AC converter
- 7 AC power line
- 8 Electric meter
- 9 Potential equalisation
- 10 Public grid



## Why should I invest in solar today?

- Solar energy systems reduce up to 100 % your electricity costs, depending on system size. Utility prices are only going up every year. Solar energy provides you security from rising electricity rates.
- A solar electric system adds value to any home or building and pays for itself for years to come. And, your solar system adds value without increasing your property taxes.
- Solar is an environmentally responsible technology. Unlike fossil fuels, it does not emit pollutants which create harm to people and the environment.
- The current state and federal incentives for solar can save 30–50 % of your system cost. State rebates can drop every six months, so make your reservation now!
- It is a proven technology with panels that are backed by a 25-year manufacturer warranty.
- Solar energy systems can provide electricity in villages and other regions which have no own electricity for all kind of use.

### Example of a 500 kW SunPower plant in Northern Germany

- Location: Northern Germany
- Nominal Capacity: 500 kWp
- Adjustment: 0°
- Falling gradient: 30°
- Prognosticated annual return of the 500-kWp-plant: about 414.000 kWh/year
- 351.900 kg CO<sub>2</sub> prevention per year – active environment protection!

Daily energy benefit of the system

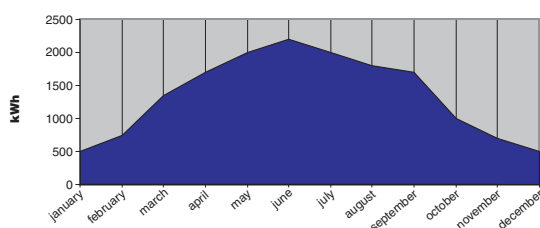

## **STEINER Technology Group (STG) GmbH**

Offers since 1993 international consultation in the sector environmental engineering and all kinds of engineering works. Located in Wilnsdorf/ Germany Steiner Technology Group (STG) GmbH attends your projects completely from the planning over the engineering/construction, approval and project management until the day of starting up.

### **We offer the following services:**

- Consulting, engineering and contracting for innovative and renewable energies
- Design and delivery and assembly of environmental technology, sewage technology, water technology and construction engineering
- Design and delivery and assembly of complete wind power plants
- Design and construction of complete wastewater treatment plants, desalination plants etc.
- Engineering and transfer of technology of the railway business
- Design and construction of railway vehicles/rolling stock material/bogies and freightcars



### **STEINER Technology Group (STG) GmbH**

Dortmunder Straße 7

57234 Wilnsdorf · Germany

Phone: +49 (0) 27 39 / 40 39-0

Fax: +49 (0) 27 39 / 40 39-24

[www.steiner-technology.de](http://www.steiner-technology.de)